

Kern Energy Project Summary

Project At-a-Glance

- What is being proposed? Kern Energy is proposing to leverage its existing infrastructure, by integrating a hydrogen purification system to generate zero emissions electricity that will improve facility efficiency while reducing its environmental footprint.
- Why is this being done? To generate on-site electricity through zero emissions fuel cells, utilizing an existing source of hydrogen.
- What equipment will be added? A purification unit, a storage system, and fuel cells that generate electricity will all be integrated within the facility infrastructure.
- What are the emissions? Fuel cells produce zero emissions of nitrogen oxides (NOx), particulate matter (PM), sulfur oxides (SOx), carbon monoxide (CO), and volatile organic compounds (VOC). Small amounts of VOC emissions may occur from new piping components, which will be inspected and maintained under strict rules.
- Are there health risks? A health risk review found that the project's emissions are below all State and District thresholds.

Project Proposal

Kern Energy has applied for Authority to Construct permits to install power generation equipment utilizing fuel cell technology (Project). The fuel cells will generate zero emissions electricity, utilizing the hydrogen that is currently generated within the existing refining process.

Process Description

The Project involves installing the following systems:

- A hydrogen purification system,
- Hydrogenation and dehydrogenation systems, and
- Fuel cell electrical generators utilizing purified hydrogen

Hydrogen is currently co-produced at the facility as an inherent part of existing refinery operations. The new purification unit will clean the hydrogen by removing hydrocarbons. The purified hydrogen can then be directed to the new fuel cells to generate electricity or sent to a new system that stores hydrogen at atmospheric conditions for later use. Hydrocarbons removed during the purification process are returned to existing fuel systems at the facility.

The facility will also be able to safely store and then utilize the purified hydrogen as needed via new hydrogenation and dehydrogenation systems. Instead of storing hydrogen as a gas, the project will use a process that temporarily binds hydrogen into a liquid form that is safer and easier to store. In this process, purified hydrogen is combined with toluene to create methylcyclohexane. Methylcyclohexane is a stable liquid at ambient temperatures and can be stored in tanks. When hydrogen is needed, the methylcyclohexane is converted back into hydrogen and toluene. The purified hydrogen can then be used in the fuel cells to generate zero emissions electricity, and the toluene is reused in the system. See process flow diagram below.

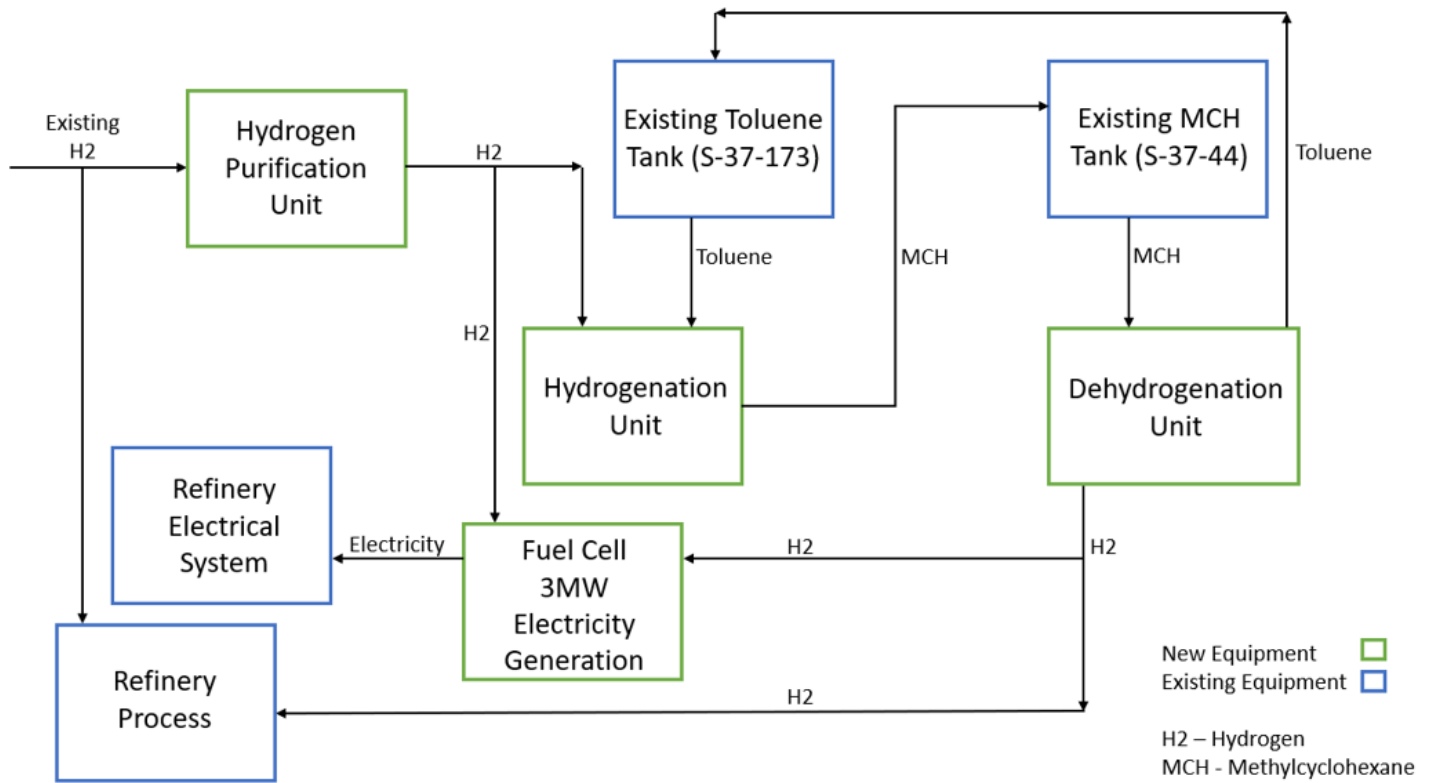

Fuel Cell Technology

Fuel cells generate electricity by combining hydrogen with oxygen in an electrochemical reaction without combustion. This makes them one of the cleanest forms of onsite power generation. Per the manufacturer, the proposed PureCell Model 400 Hydrogen units produce zero emissions for NOx, PM, SOx, CO, and VOCs. Because these fuel cells are zero emissions units, they are exempt from District permitting requirements, though they will be listed on the new hydrogen recovery unit permit for transparency. The diagram below shows how a hydrogen fuel cell converts purified hydrogen into clean, reliable electricity.

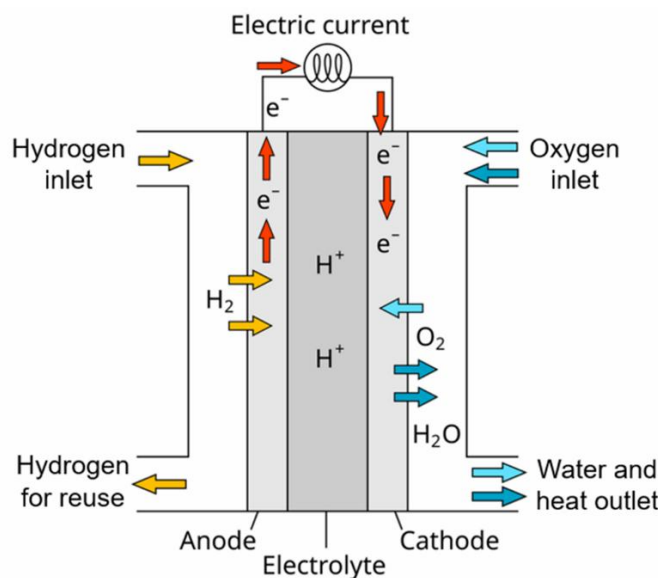

Emission Sources and Emission Control Equipment

The new systems will be connected by piping with valves, seals, and fittings. These components can release small amounts of VOCs. Although part of the system carries hydrogen, which is not a regulated air pollutant, the District is conservatively assuming that all new components could contain VOC to ensure protective evaluation. To control these potential emissions, the components associated with the Project are subject to Best Available Control Technology for VOC emissions. The components will be routinely inspected for leaks, and any leaks must be repaired quickly in accordance with District Rule 4455 (*Components at Petroleum Refineries, Gas Liquids Processing Facilities, and Chemical Plants*).

Facility Emission Rates

The Project is expected to emit approximately 1.3 pounds of VOCs per day (equivalent to 483 pounds of VOC per year), all from fugitive emissions in the piping components. This amount is considered low and is calculated using standard statewide emission factors.

Health Risk Management Review

A health risk analysis was completed using conservative State-approved methods to evaluate potential health impacts to nearby residents and workers. The review found that the project's emissions are below all State and local thresholds for cancer risk, chronic health effects, and short-term (acute) health effects.

Although the project does not trigger additional toxic control requirements, it meets the standards for Toxics Best Available Control Technology.

California Environmental Quality Act (CEQA)

Kern County is the Lead Agency for CEQA and determined that the project qualifies as a ministerial action, meaning it follows a fixed permitting process without discretionary decision-making. As a result, the County filed a Notice of Exemption.

The District's review focused only on air quality impacts. The engineering evaluation confirmed that the project complies with all applicable Federal, State, and local air quality rules and regulations.